

Next, move the cursor within the circle that defines the left end of the axle.

Since this face is really hidden in this view, touch the **[ENTER]** Key once to index the Face Selector to this face.

When the face highlights, click on it.

(HINT: If you have trouble picking this face, use the **Hot Key [W]** to access the ZOOM Tool. Then, drag a small selection box around this area so that it is magnified.)

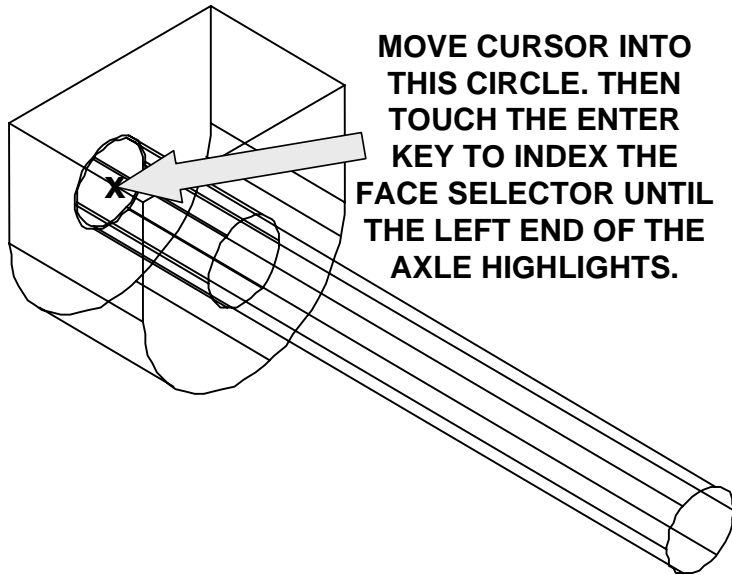

The left end of the axle will now extend out from the left bearing block by 0.5 inches.

Now it's time to paste one of our wheels that we created in our other file into this file!

Now, click on the word "WINDOW" in the row of words at the top of the CAD screen.

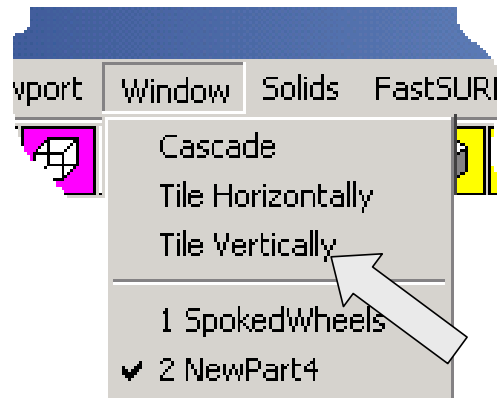

You will notice that both files that you have been working on appear in the pulldown list. You will also see three Options.

Click on the TILE VERTICALLY Option.

You will see both of your files appear side by side. The file that has a color bar visible at the top is the current active one.

If you click in the viewport area of the inactive file, the color bar will become visible at the top of this file indicating that it has become the active one.



Now, let's click on a new **Hot Key [P]**. Then, click on the **CENTER** Option on the Conversation Bar.

Click in the Viewport of the file with the wagon to make it active.

Next, click on the small circle that defines the right end of the axle.

A point will appear centered in the circle. You will see in a moment how useful this point can be!

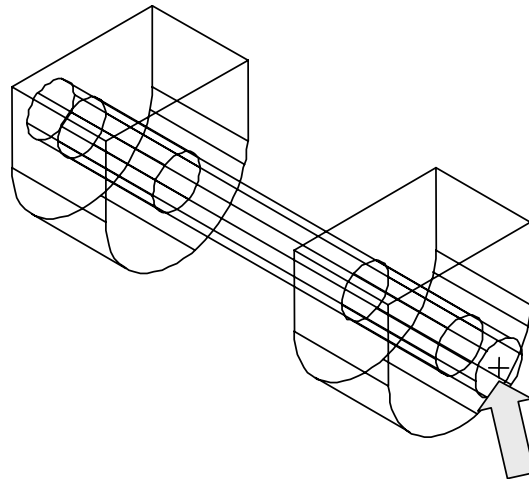

PLACE THE POINT AT THE CENTER OF THIS CIRCLE

Next, click in the Viewport of the file with the wheels to make it active.

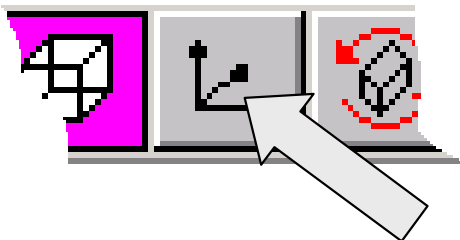

Click on the **SET VIEW** Icon and type 7 for the View Number. Hit the **[ENTER]** Key.

Use the **Hot Key [A]** to fit the profiles on the screen.

Now, once again, click on the **Hot Key [P]**.
Then, click on the CENTER Option on the Conversation Bar.

Next, click on the large circle that defines the right edge of the top wheel. A point will appear centered in the circle. Repeat this for the other two wheels. (You'll want to save this file again for permanent use with these points added so you won't have to do this again.)

Now, you will notice that the wheels are not oriented correctly with respect to the axles on the wagon. This is because the ends of the axles are facing view 5 (The right side view.) while the wheels were made starting in view 2 (The front view.)

Because we have our positioning points in place, this mismatch doesn't matter!

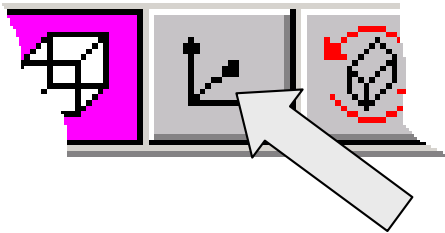

Click on the SET VIEW Icon and type 2 for the View Number.

Hit the **[ENTER]** Key. This switches the view of the wheels in the active wheel file to a profile view.

Use the **Hot Key [A]** to fit the profiles on the screen.

Now, click on the COPY Icon on the Toolbar.

Using the SINGLE Option, click on the wheel style that you would like to use. I'm going to pick the middle, six spoke wheel.

Hit the **[ENTER]** Key.

You are prompted to indicate a base position for future paste.

Click on the POINT Option on the Conversation Bar and then click on the point on the wheel that you selected.

(NOTE: Now you see the neat use of the point. In this view, if we used the CENTER Option and picked a circle, there are several circles that lie on top of each other. How could we be sure that we would get the right one? But there is only one point and we placed that point right where it would do the most good!)

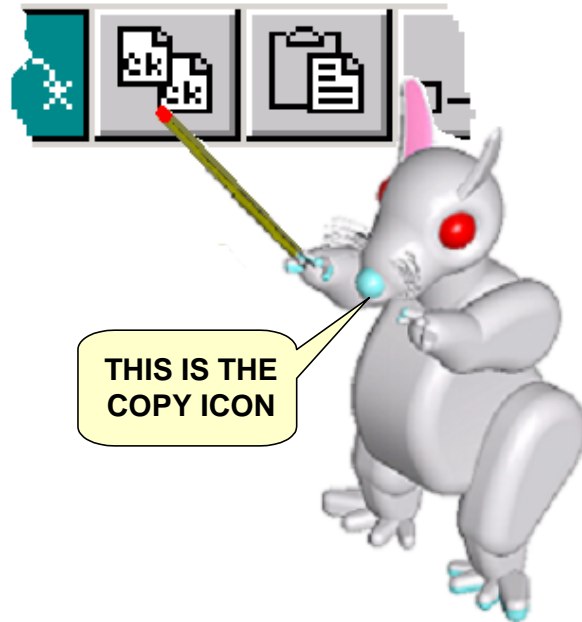

Click in the Viewport of the file with the wagon to make it active.

Click on the SET VIEW Icon and type 5 for the View Number.

Hit the **[ENTER]** Key. This switches the view of the wheels in the wagon file to a profile view of the bearing block and shaft diameters.

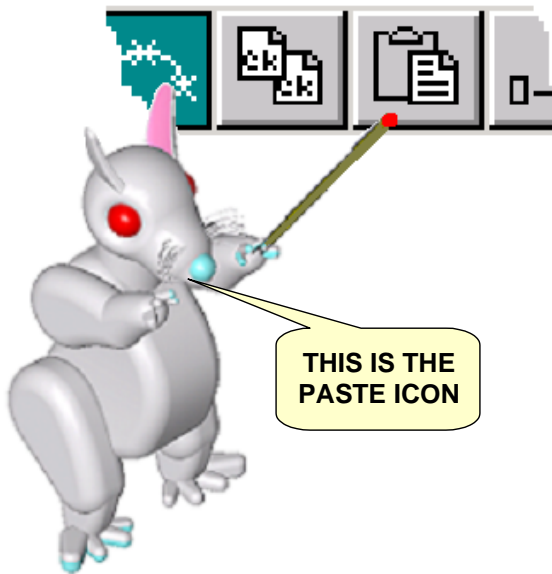
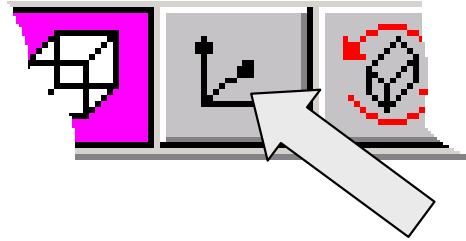

Use the **Hot Key [A]** to fit the profiles on the screen.

Now, click on the PASTE Icon on the Toolbar.

Click on the POINT Option on the Conversation Bar and then click on the point that lies on the end of the axle.

You will see the wheel appear.

Click on the SET VIEW Icon and type 7 for the View Number.

Hit the **[ENTER]** Key.

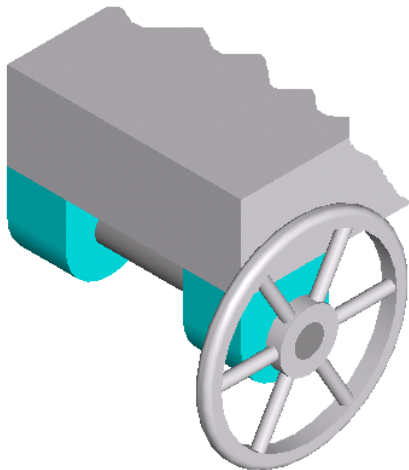
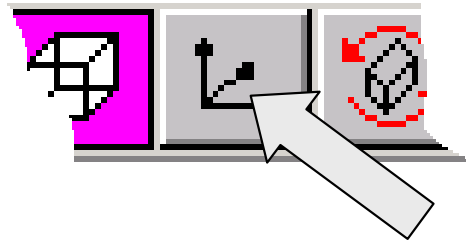

The wheel should be positioned on the end of the axle. (I've shown a rendered image of the positioned wheel to the left.)

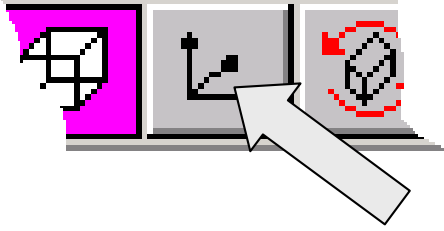

Now, click on the SET VIEW Icon and type 1 for the View Number.

Hit the **[ENTER]** Key.

Use the **Hot Key [A]** to fit the profiles on the screen.

Click on the XFORM MIRROR Menu Icon on the Toolbar.

Then, click on the XFORM MIRROR COPY Icon on the three icon Flyout that appears.

Click on the SINGLE Option on the Conversation Bar and then on the wheel.

Hit the **[ENTER]** Key.

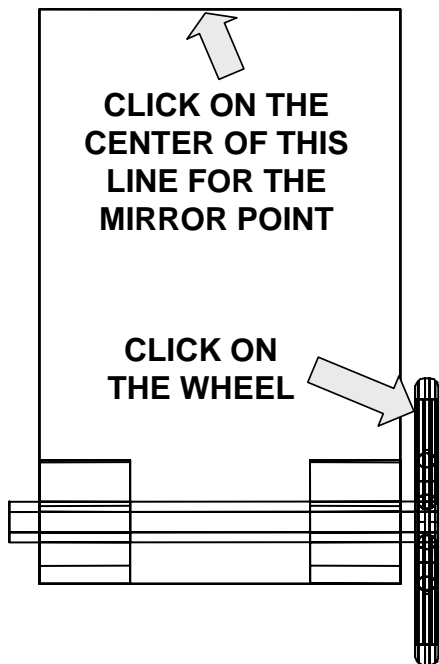
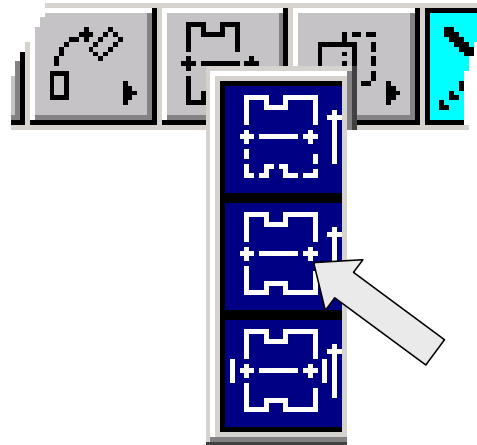

Click on the 1 PT V Option on the Conversation Bar.

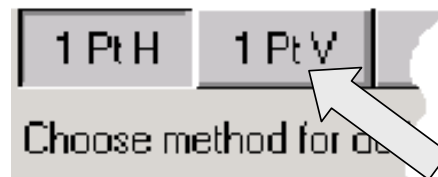

Then, using the CENTER Option, click on one of the horizontal green lines on the screen.

A copy of the wheel will appear at the left end of the axle.

We now have two bearing blocks, one axle, and two wheels at the front of our wagon. We want an exact duplicate of all of this neat stuff at the other end of the wagon. Instead of doing all this work over again, let's just copy everything we need with one quick transform!

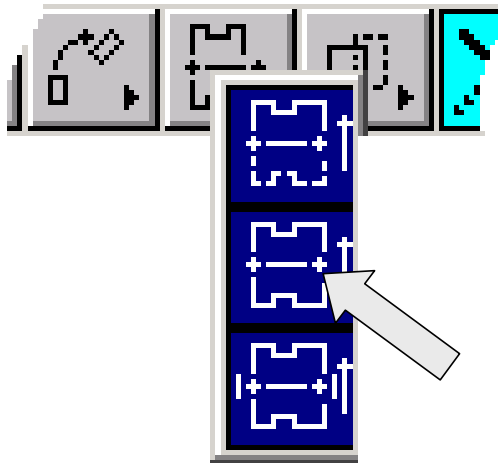

Click on the XFORM MIRROR Menu Icon on the Toolbar.

Then, click on the XFORM MIRROR COPY Icon on the three icon Flyout that appears.

Click on the WINDOW Option on the Conversation Bar.

Now, drag a selection box around all of the parts that you want to copy at the bottom of your screen.

Be sure to keep the top edge of the selection box below the top green line so that the wagon body itself is not included in the selection.

Click on the 1 PT H Option on the Conversation Bar. Then, using the CENTER Option, click on one of the vertical green lines on the screen.

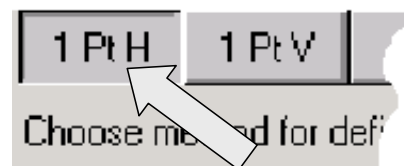

A complete copy of all of the objects selected appears at the other end of the wagon!

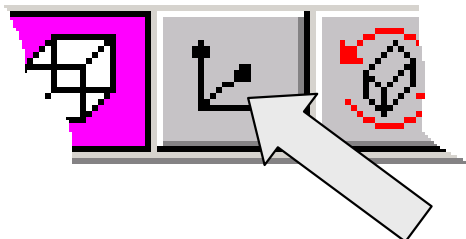

Now, click on the SET VIEW Icon and type 7 for the View Number.

Hit the **[ENTER]** Key.

Use the **Hot Key [A]** to fit the profiles on the screen.

Click on the RENDER WITHOUT WIRE Icon to get a smooth shaded model.

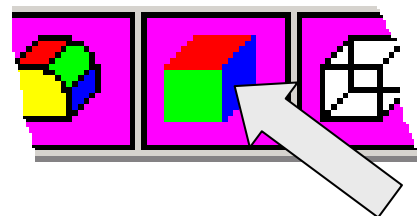

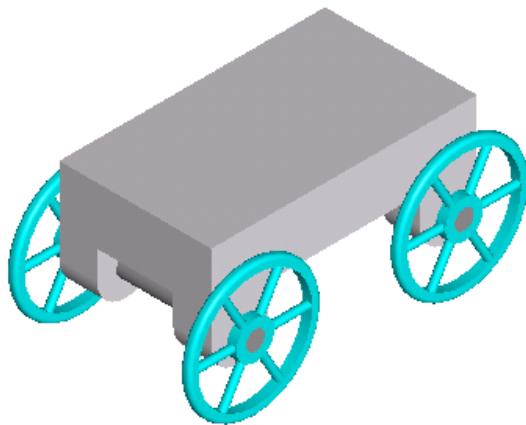

Your wagon should look like this:

We have one last task. We need to hollow out the wagon body.

To do this, click on the SHELL Icon.

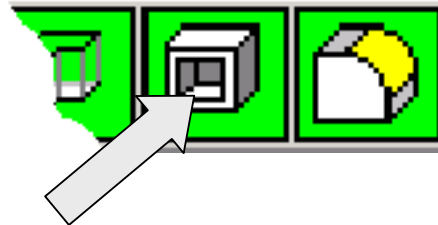

A Dialog Box appears.

Type 0.2 for the wall thickness and click on the OK Button.

Then, move the cursor over the top surface of the wagon body until it highlights.

Click on the highlighted surface.

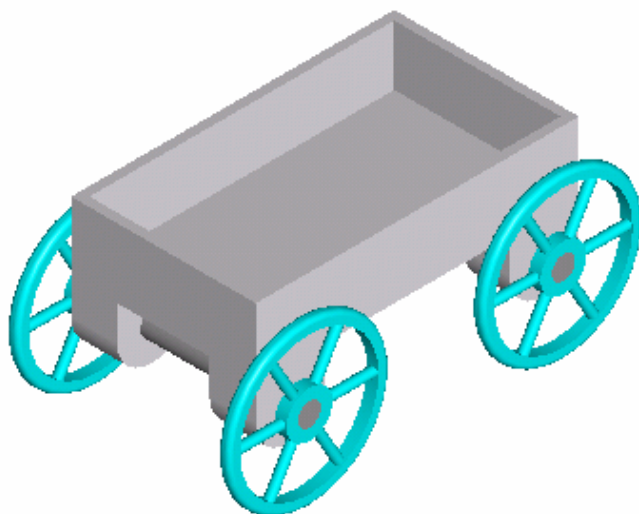
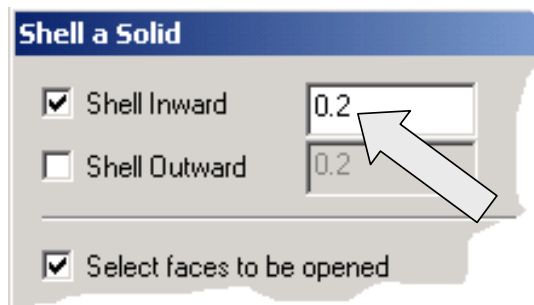

Your completed wagon should look like this:

Don't forget to save your file by clicking on the FILE SAVE Icon.

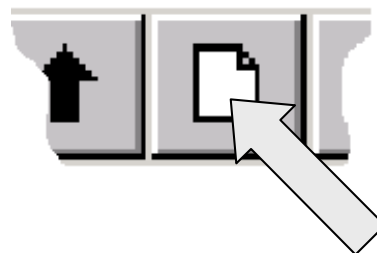

EXTRA CREDIT:

If you still have a copy of the cheese that you made, try copying the cheese from the file it is in and placing it in the wagon. Doctor Walt would love a cheese wagon!

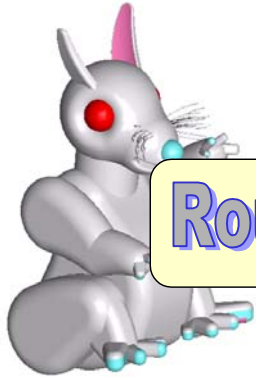

Before we move on, let's review what we have learned.

- **We used the powerful XFORM Tools to create three styles of wheel in one file.**
- **We then learned how to copy an object, like a wheel from one file and paste it into a second file.**
- **We used the CREATE POINT Tool to make reference points that helped us position objects in three-dimensional space.**
- **We used the powerful Construction Plane Function to locate parts in three-dimensional space.**
- **We learned that with a little careful planning it is quite easy to assemble multiple objects to make a more complex assembly like our wagon.**

The wagon that we built is pretty simple compared to a fancy car.

The approach we use to duplicate the bearing blocks and wheels is the same.

Once you master these ideas, you will be able to create really cool cars!

